

REV	ECN	DATE	BY	CHANGE OR ADDITION
A	1102	10/4/2013	LUND	UPDATED WITH WIDE FOOT PAD, DUAL DIMENSIONS, STANDARDIZED TITLE

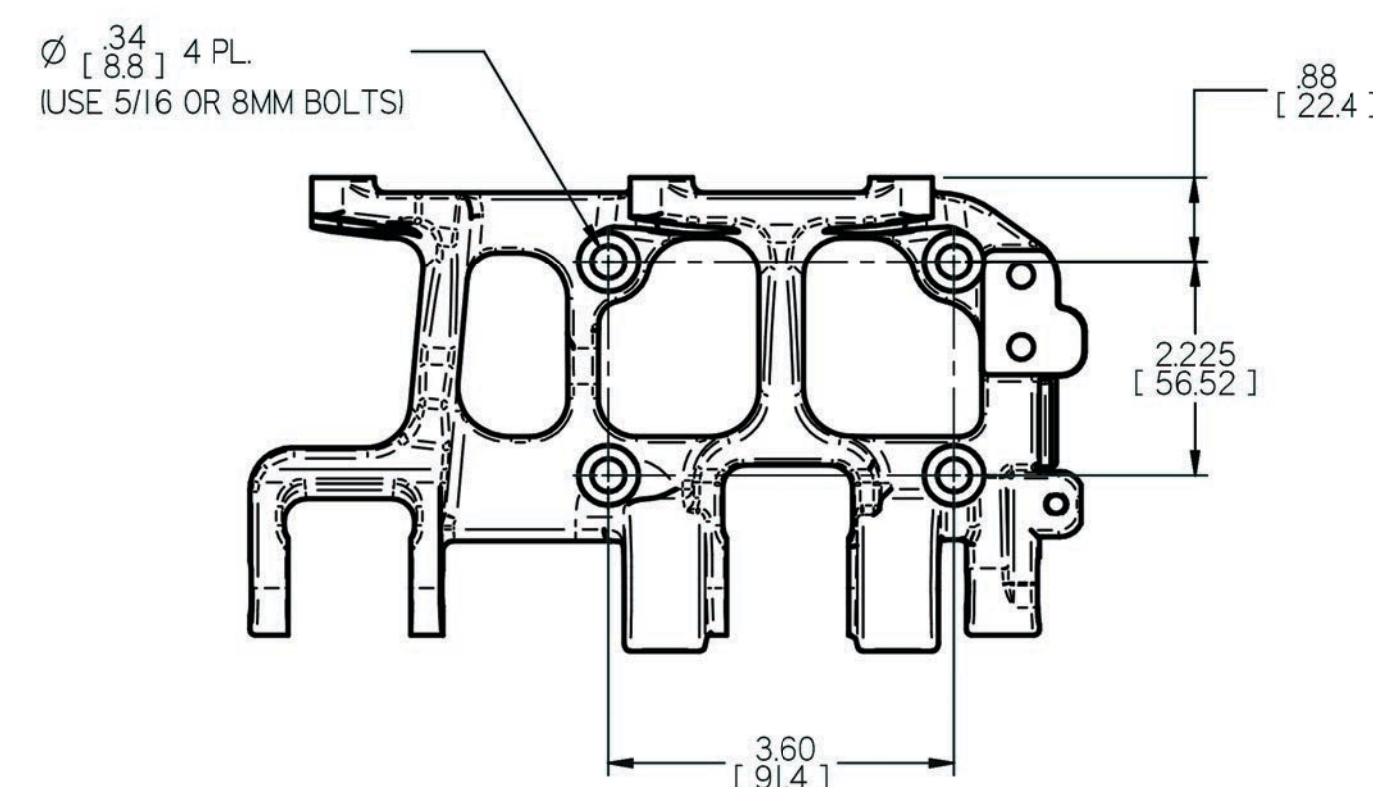
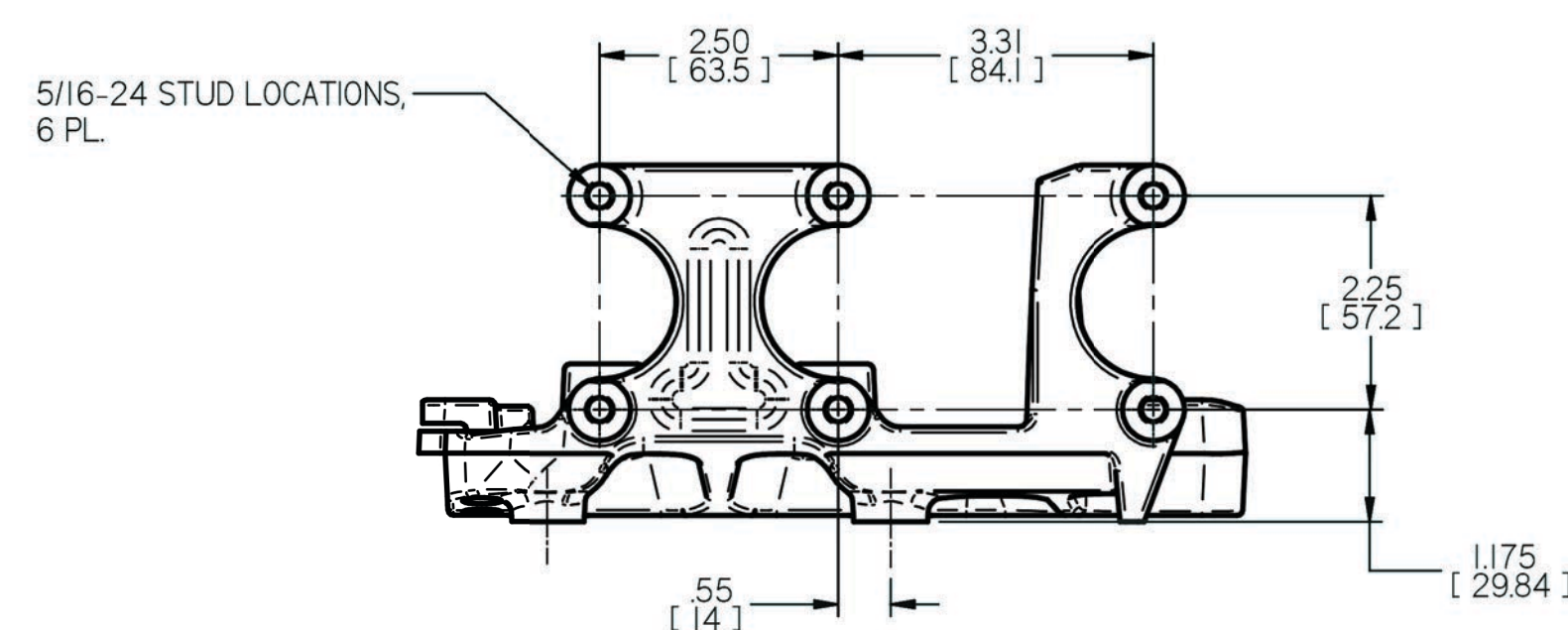
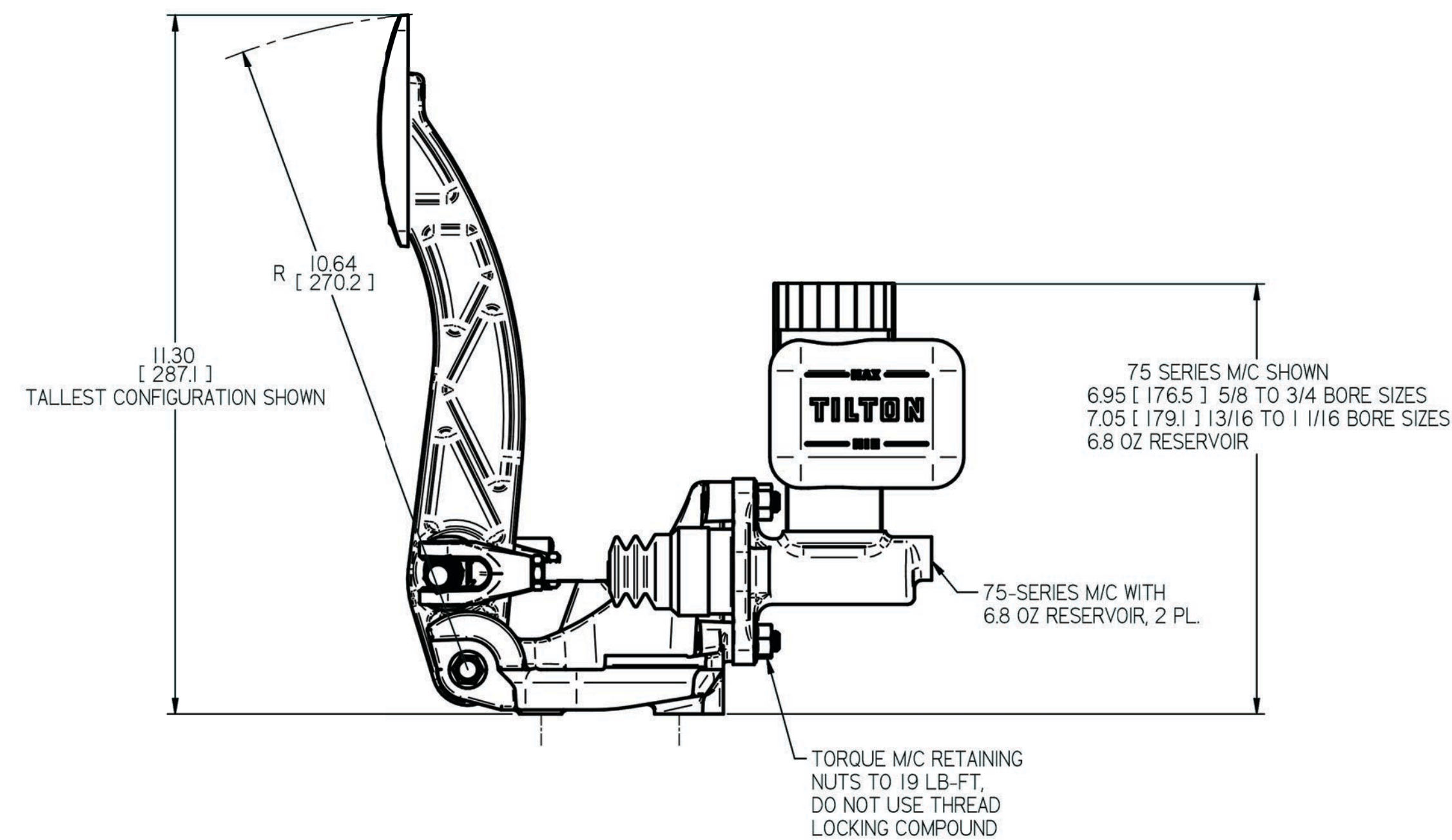
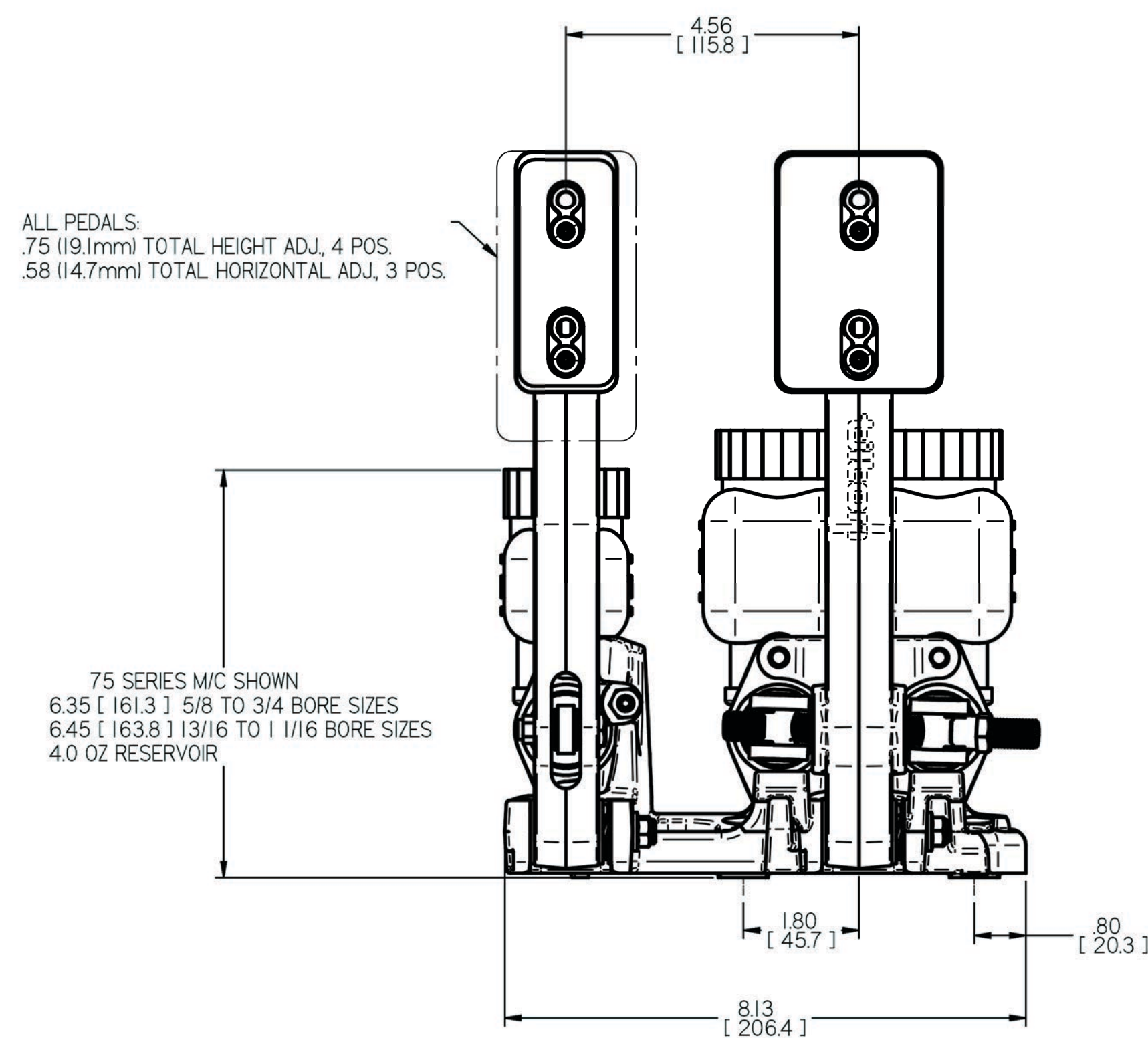
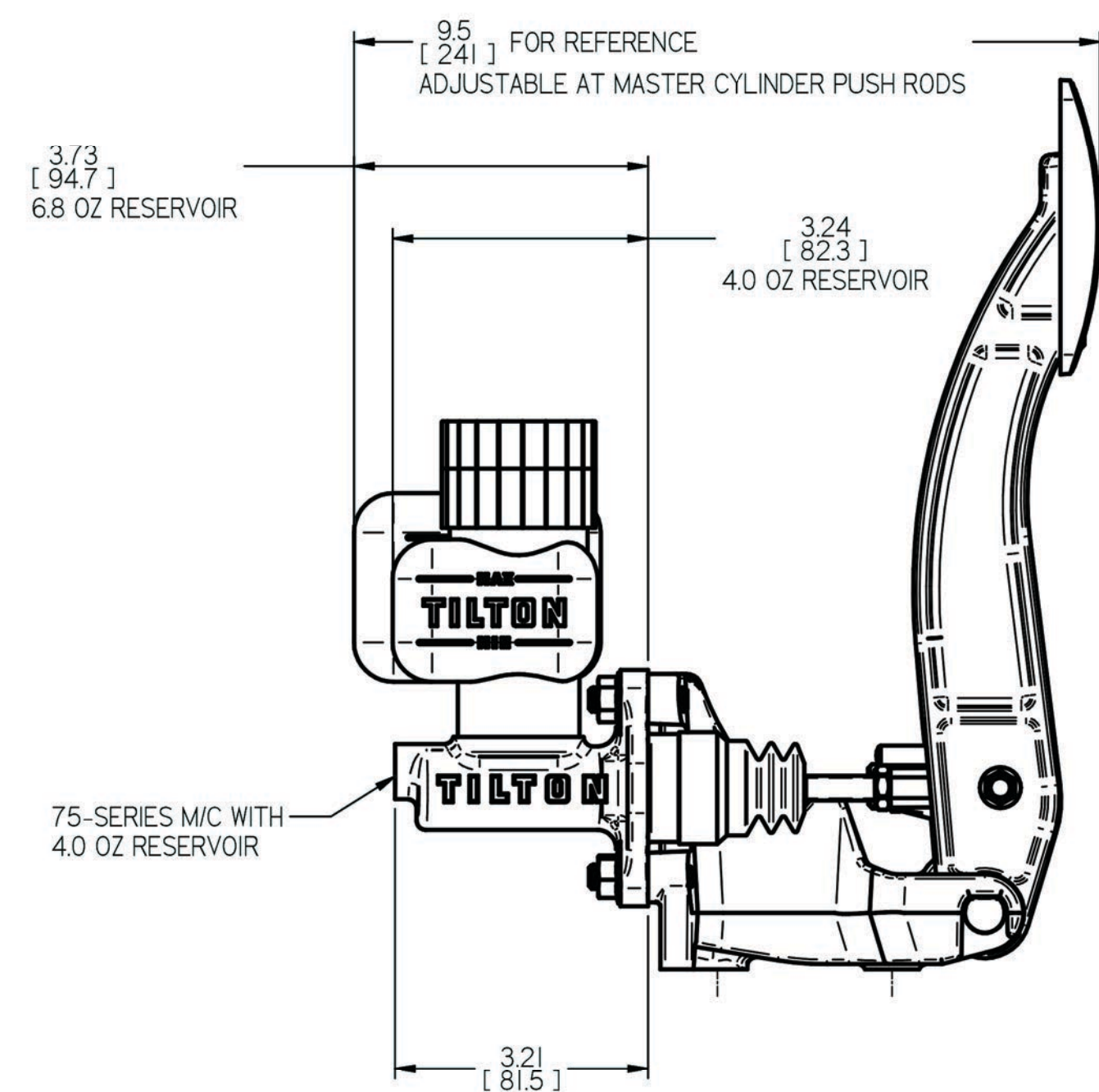
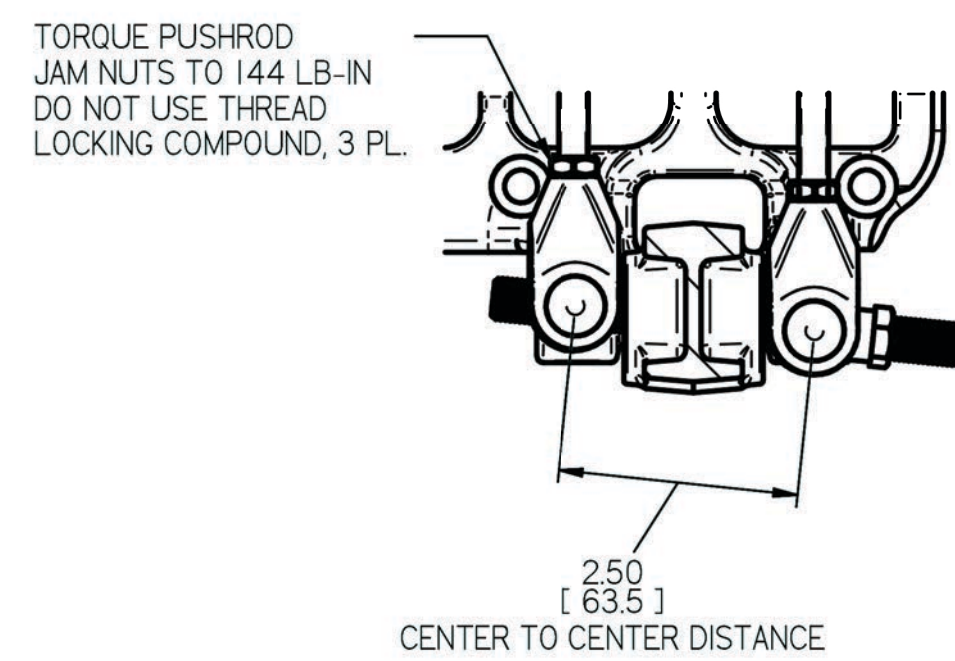
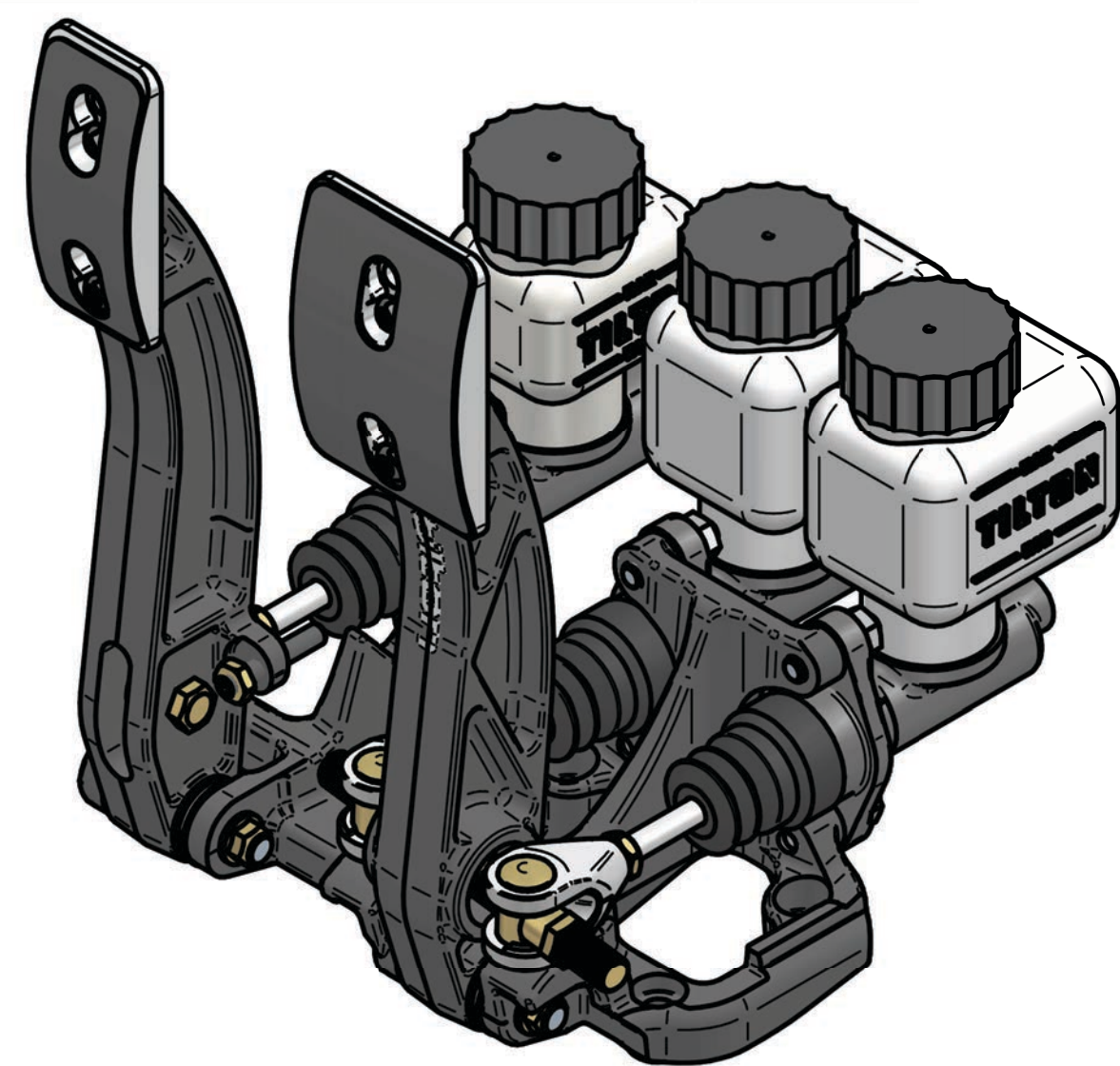

- NOTES:
1. DIMENSIONS AND TOLERANCES PER ASME Y14.5 - 2009
 2. UNLESS OTHERWISE SPECIFIED, ALL DIMENSIONS ARE IN INCHES [MM].

TILTON ENGINEERING, INC.		(805) 688-2353 FAX (805) 688-2745	
25 EASY STREET P.O. BOX 1787		BUELLTON, CALIFORNIA 93427 USA	
TITLE: PEDAL ASSEMBLY, 600-SERIES FLOOR MOUNT, 2 PEDAL, ALUMINUM (INSTALLATION DRAWING)			
DRN BY	SCHANK	CHK'D	SCALE 1:1
P/N	72-604	DATE	04/25/08
SHEET 1 OF 1		DWG	5316
		REV	A

This document contains proprietary information of TILTON ENGINEERING, INC., and its receipt or possession does not convey the rights to reproduce, disclose its contents, or to manufacture, use or sell anything it may describe. Reproduction, disclosure, or use without specific written authorization of TILTON ENGINEERING, INC. is strictly forbidden.

TILTON ENGINEERING INC.